

November 26, 2024

Reference: CSIO/MSSA/HCP0057/168

Subject: Call for Expression of Interest (EoI)/quotation for the purchase of goods/fabrication job work for the ongoing project activities- reg

It is informed that the following items are proposed to be purchased /fabricated. Interested parties are requested to **submit a quotation** through email/hard copy to the undersigned **within the next three days** from the date of publishing of the notice.

Items/Goods/Job work required

| Sr. No. | Description of the items/Goods/Jobwork | Quantity |
|---------|---|----------|
| 1. | Fabrication of Nitrate Sensor Component as per the attached. (Annexure-I) | 01 |

Terms and Conditions:

Delivery: For CSIR-CSIO, Chandigarh

Lead time/delivery time: 4-6 weeks

Payment: After delivery and successful inspection



Dr Babankumar S. Bansod
Senior Principal Scientist & Project Leader
9888520252; scientist_babankumar@csio.res.in

HEAD ISD, with a request to display on the CSIO website

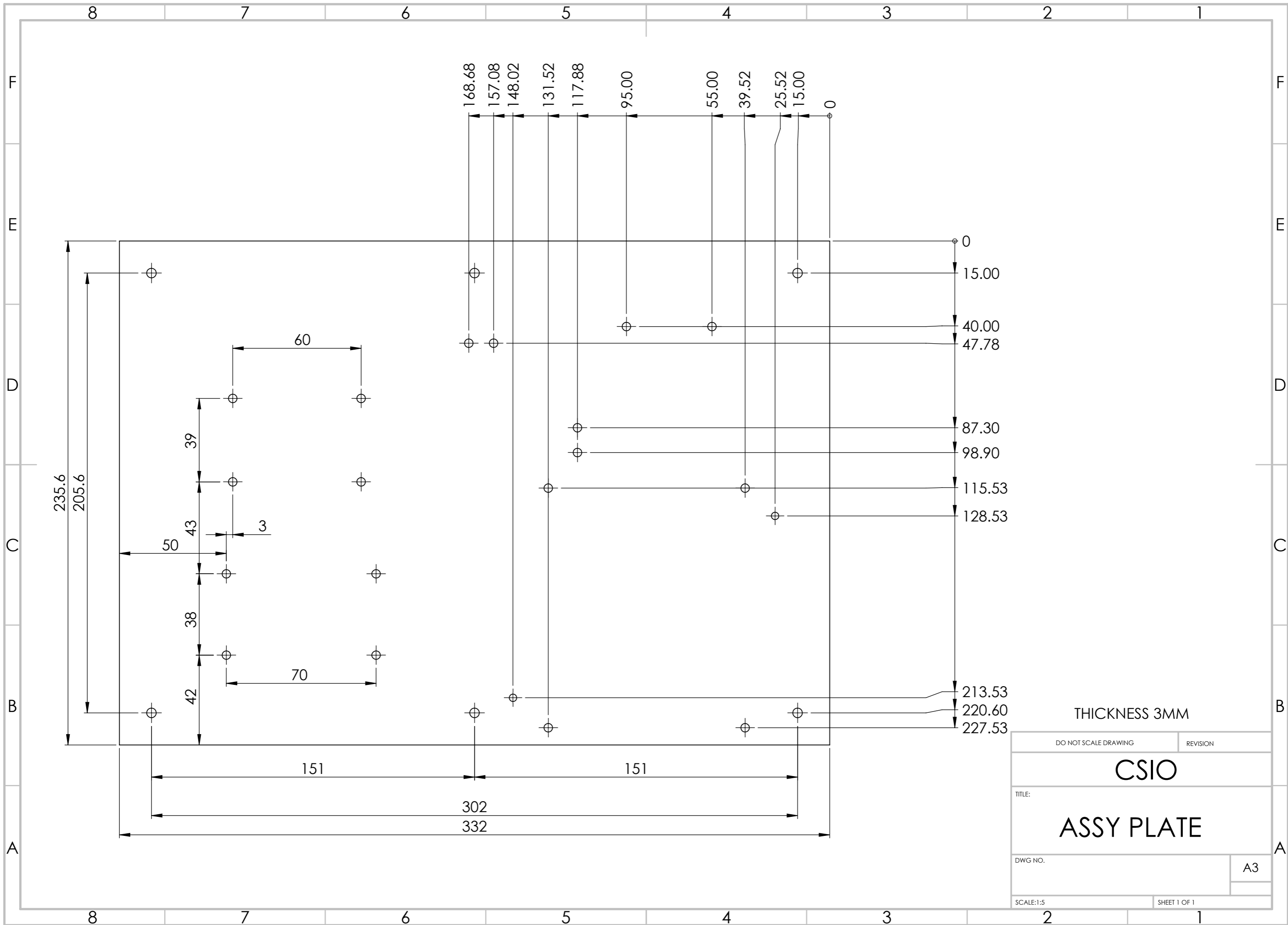

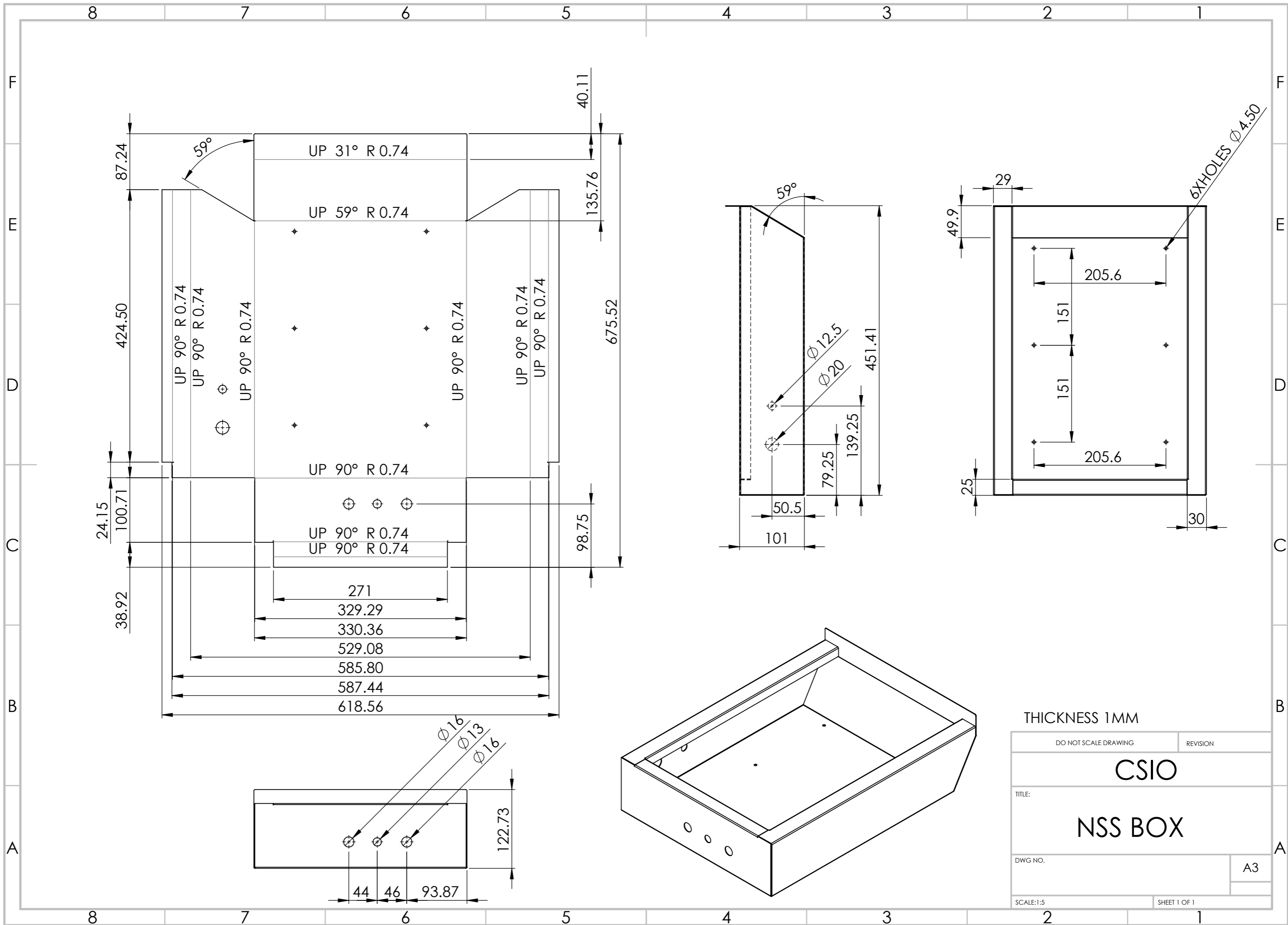

THICKNESS 1MM

| | | |
|--------------------------|--------------|----------|
| DO NOT SCALE DRAWING | | REVISION |
| CSIO | | |
| TITLE: NSS BOX | | |
| DWG NO. | A3 | |
| SCALE:1:5 | SHEET 1 OF 1 | |

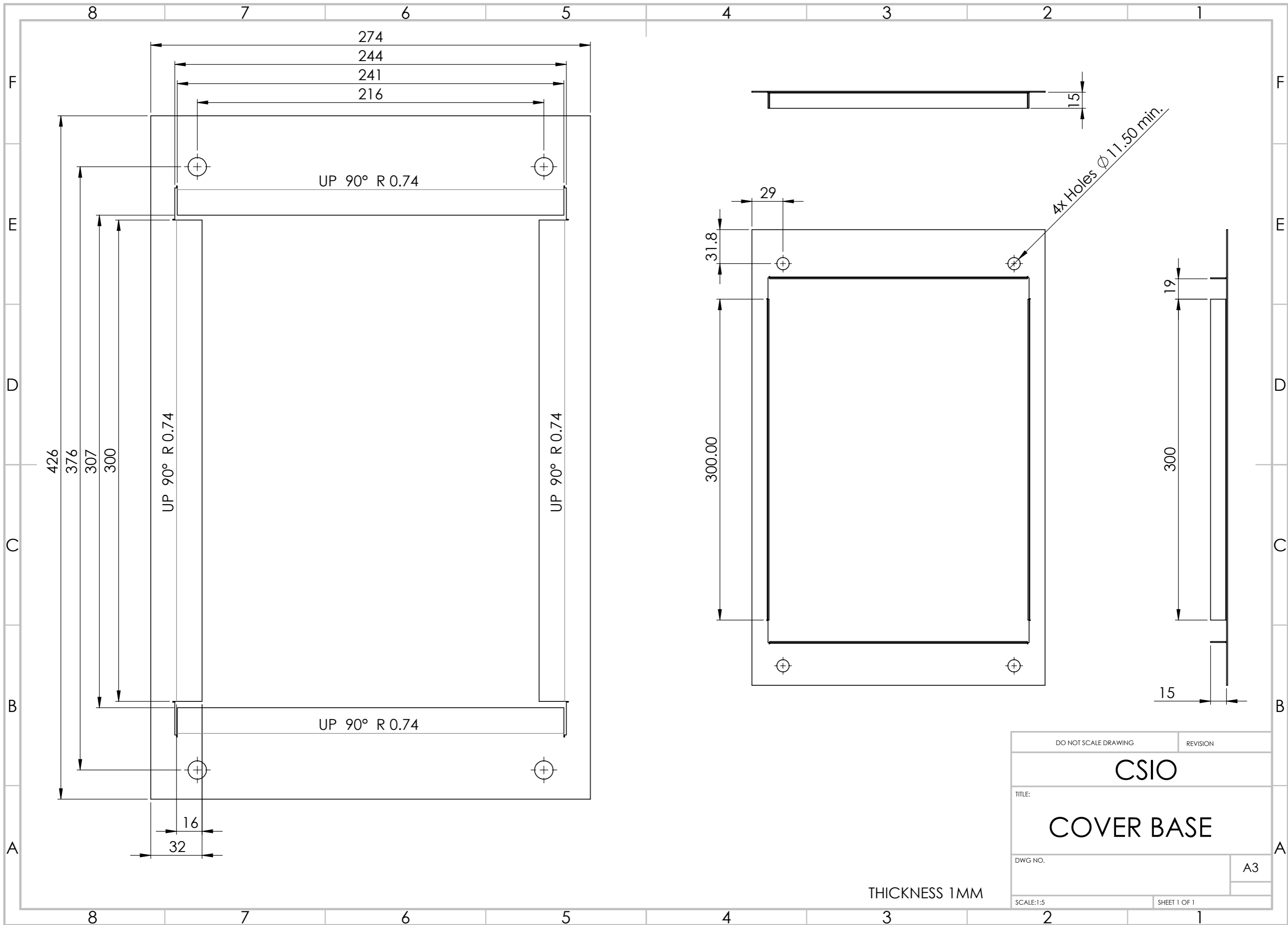

THICKNESS 1MM

| | | | |
|----------------------|--|--------------|----|
| DO NOT SCALE DRAWING | | REVISION | |
| CSIO | | | |
| TITLE: | | | |
| COVER BASE | | | |
| DWG NO. | | | A3 |
| SCALE:1:5 | | SHEET 1 OF 1 | |

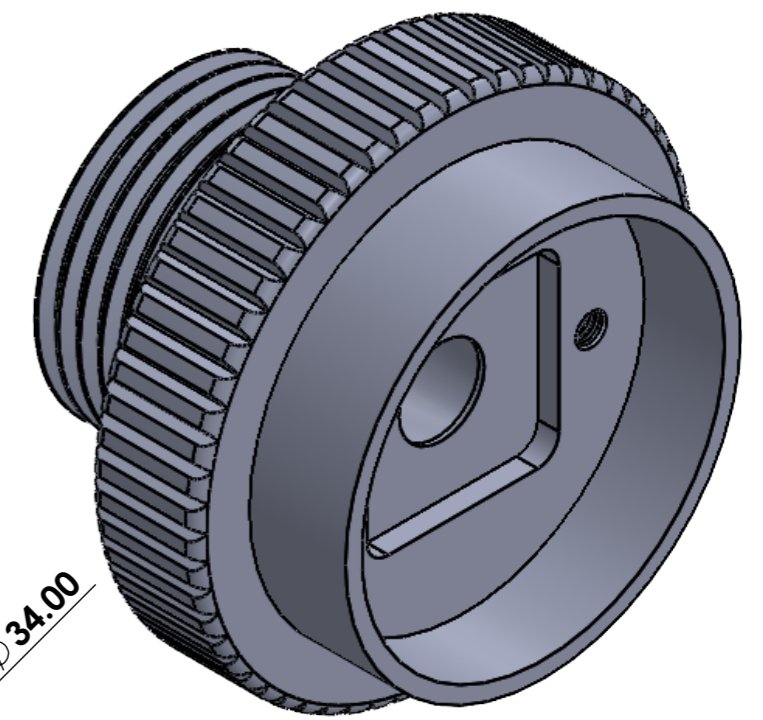
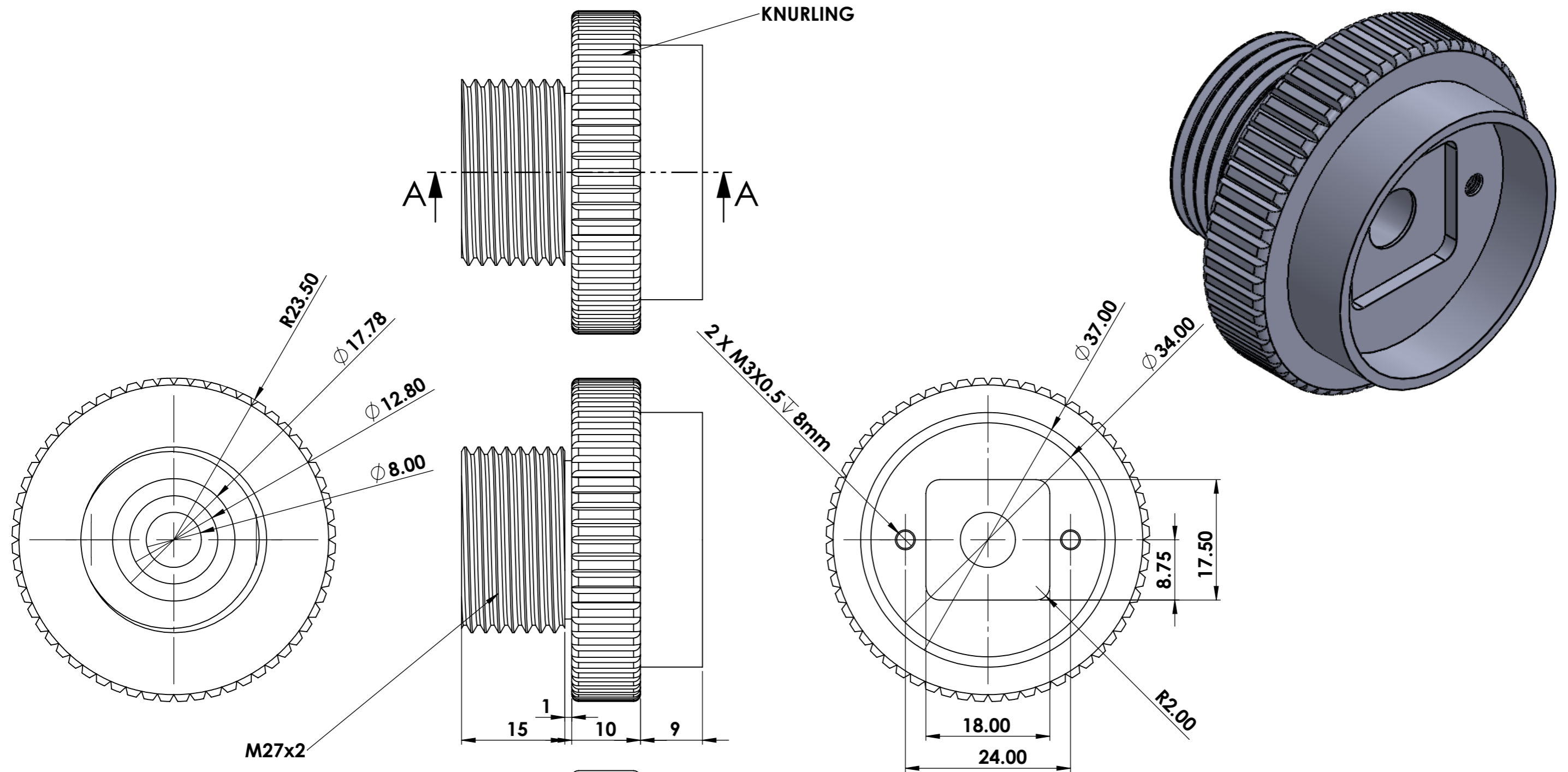

SECTION A-A

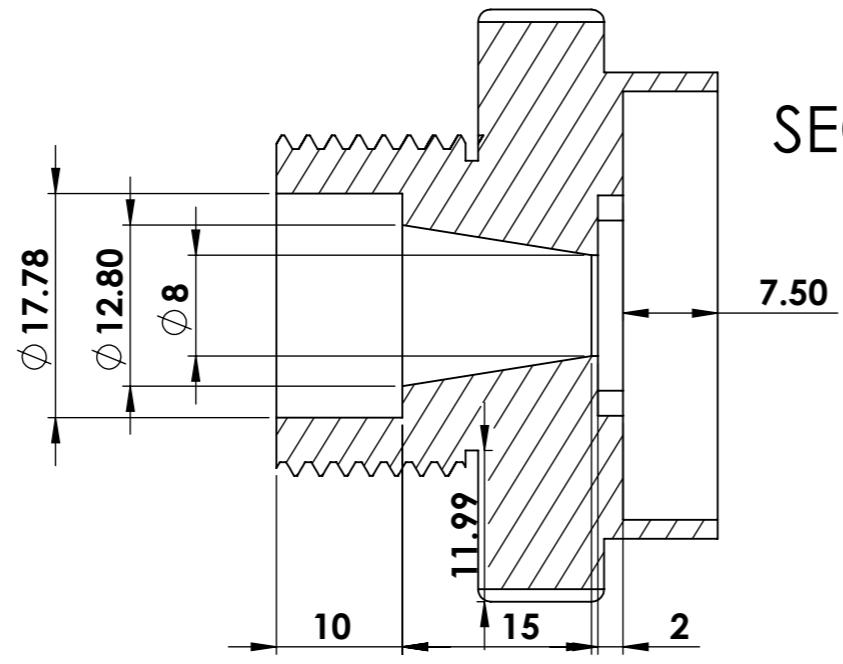

| | | | | | | | | | |
|--|--|--|--|-----------------------------------|--|---|--|--------------|--|
| ALL DIMENSIONS ARE IN MM USE GENERAL TOLERANCE CHART (FINE) | | | | DEBUR AND BREAK SHARP EDGES | | DO NOT SCALE DRAWING | | QUANTITY=01 | |
| | | | | | | CSIR-CSIO | | | |
| | | | | | | TITLE: | | | |
| | | | | | | DETECTOR SIDE ADAPTER | | | |
| | | | | | | DWG NO. CSIO/MDF/JJM/1086/2022/002 | | A4 | |
| | | | | | | SCALE: DO NOT SCALE DRAWING | | SHEET 1 OF 1 | |

| | | | | | |
|--------|------------------|-----------|-----------|--|--|
| | NAME | SIGNATURE | DATE | | |
| DRAWN | ANIL | | | | |
| CHK'D | SAGAR | | | | |
| APPV'D | Project Incharge | | | | |
| MFG | | | | | |
| Q.A | | | | | |
| | | | MATERIAL: | | |
| | | | AL | | |
| | | | WEIGHT: | | |

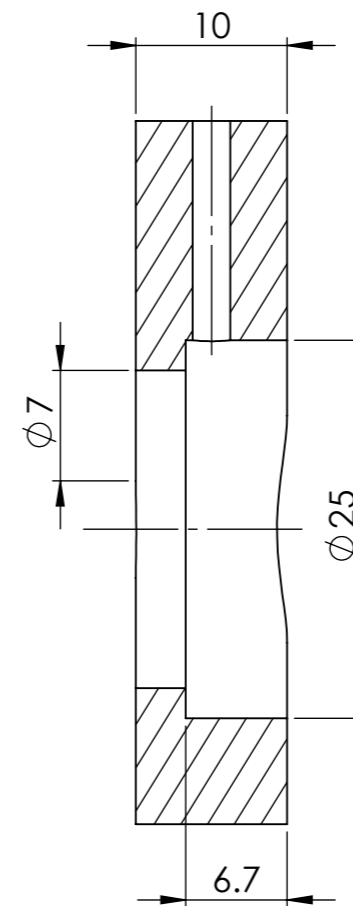
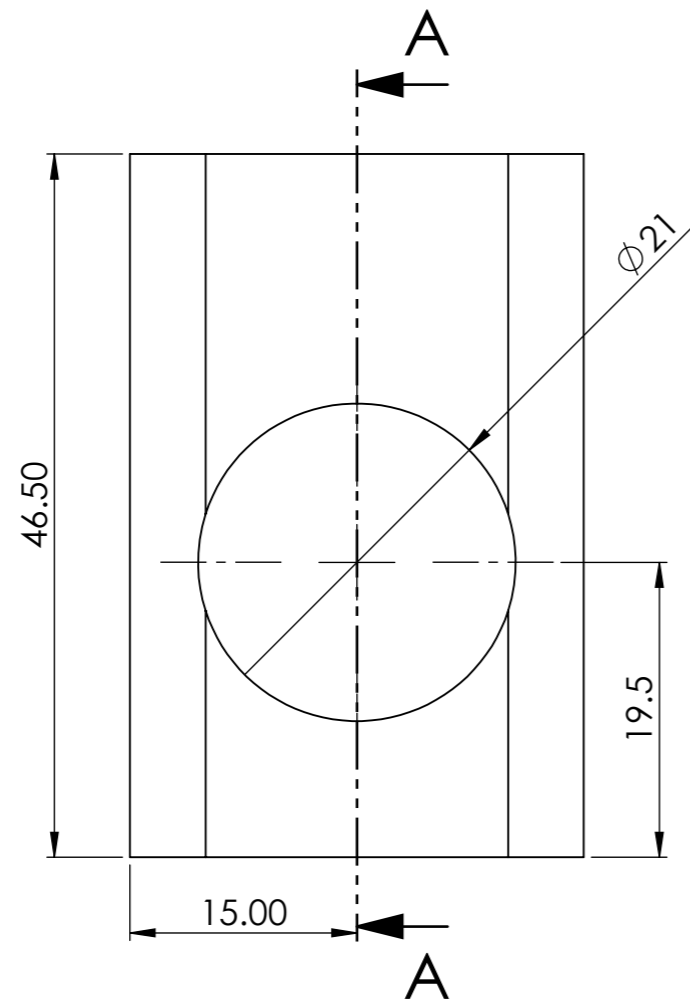
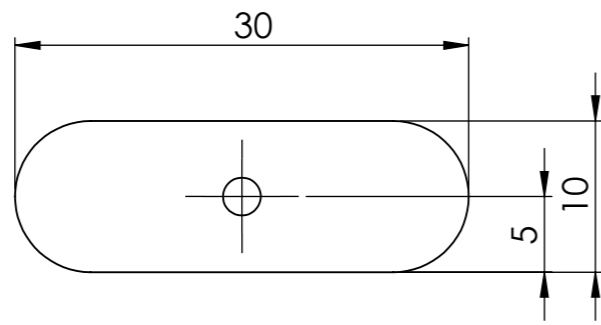

SECTION A-A

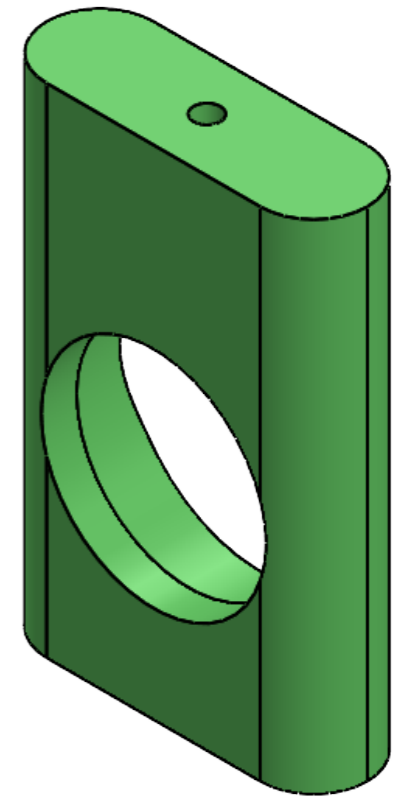

ALL DIMENSIONS ARE IN MM
USE GENERAL TOLERANCE CHART (FINE)

DEBUR AND
BREAK SHARP
EDGES

DO NOT SCALE DRAWING

QUANTITY=01

| | NAME | SIGNATURE | DATE | | |
|--------|------------------|-----------|------|-----------|--|
| DRAWN | ANIL | | | | |
| CHK'D | SAGAR | | | | |
| APPV'D | Project Incharge | | | | |
| MFG | | | | | |
| Q.A | | | | MATERIAL: | |
| | | | | AL | |
| | | | | WEIGHT: | |

| | | |
|-----------------------------|-----------------------------------|----|
| TITLE: | CSIR-CSIO | |
| | FILTER | |
| DWG NO. | CSIO/MDF/JJM/1086/2022/004 | A4 |
| SCALE: DO NOT SCALE DRAWING | SHEET 1 OF 1 | |

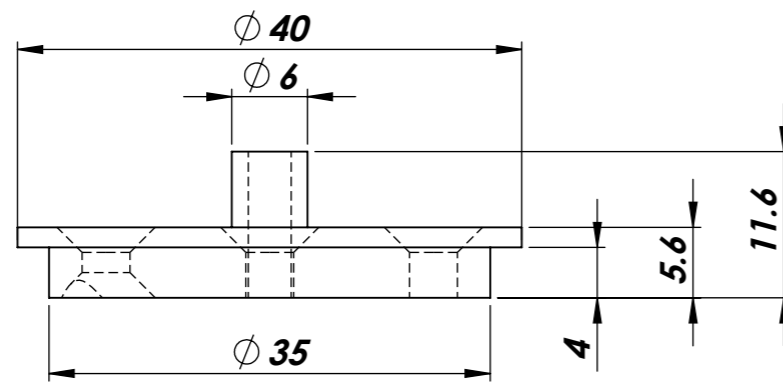
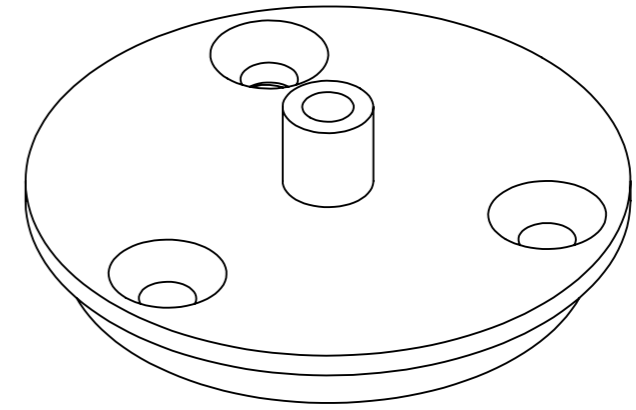
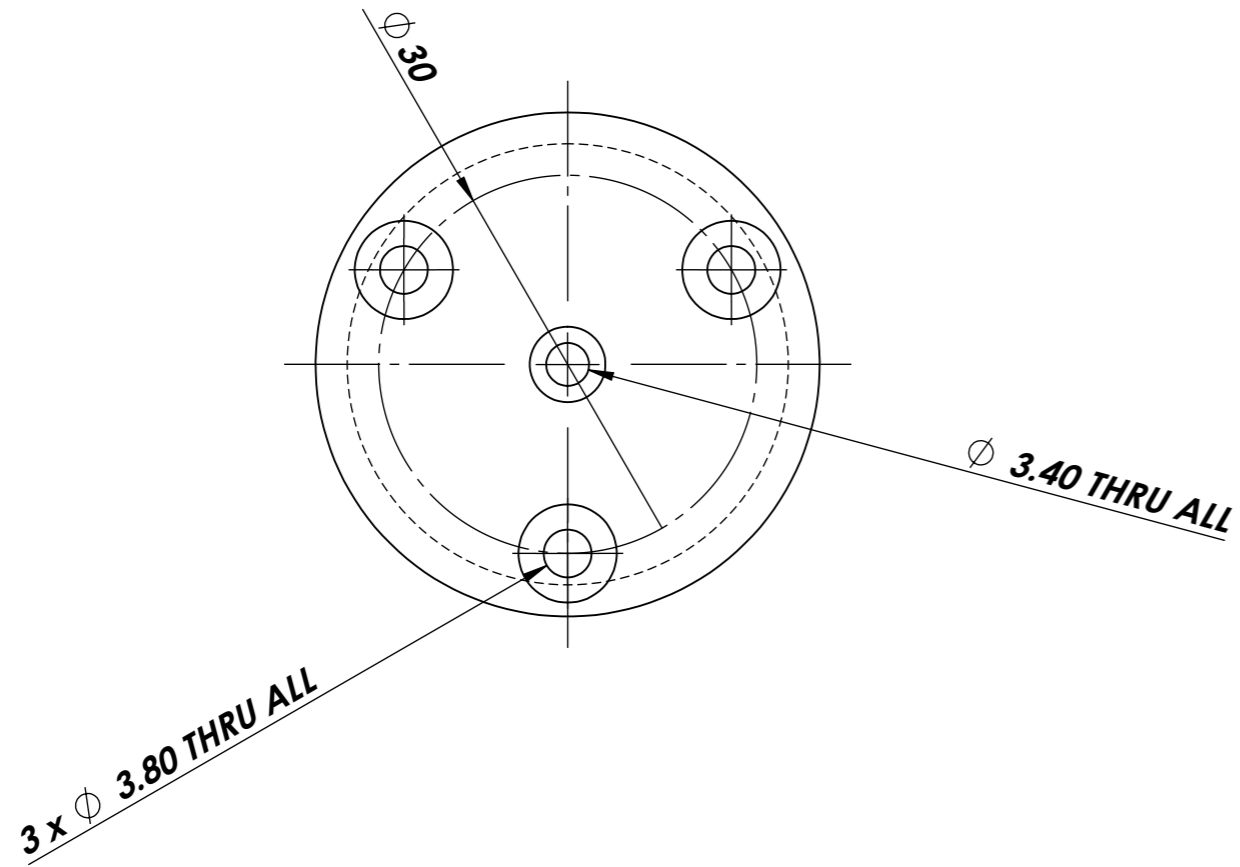

| General Tolerances | | | | Debur all sharp edges | |
|-----------------------------|------------------|-----------|------|-----------------------|--|
| Linear Dimension Range (mm) | | | | | |
| 0.5 up to 3 | +/- 0.02 | | | | |
| Over 3 upto 6 | +/- 0.02 | | | | |
| Over 6 upto 30 | +/- 0.02 | | | | |
| Over 30 upto 120 | +/- 0.1 | | | | |
| | NAME | SIGNATURE | DATE | | |
| DRAWN | ANIL | | | | |
| CHK'D | SAGAR | | | | |
| APPV'D | Project Incharge | | | | |
| MFG | | | | | |
| Q.A | | | | MATERIAL: | |
| | | | | AL | |
| | | | | WEIGHT: | |

| | |
|-----------------------------------|--------------|
| QUANTITY=01 | |
| CSIR-CSIO | |
| LAMP ADAPTOR | |
| DWG NO. | A4 |
| CSIO/MDF/JJM/1086/2022/044 | |
| SCALE: DO NOT SCALE DRAWING | SHEET 1 OF 1 |

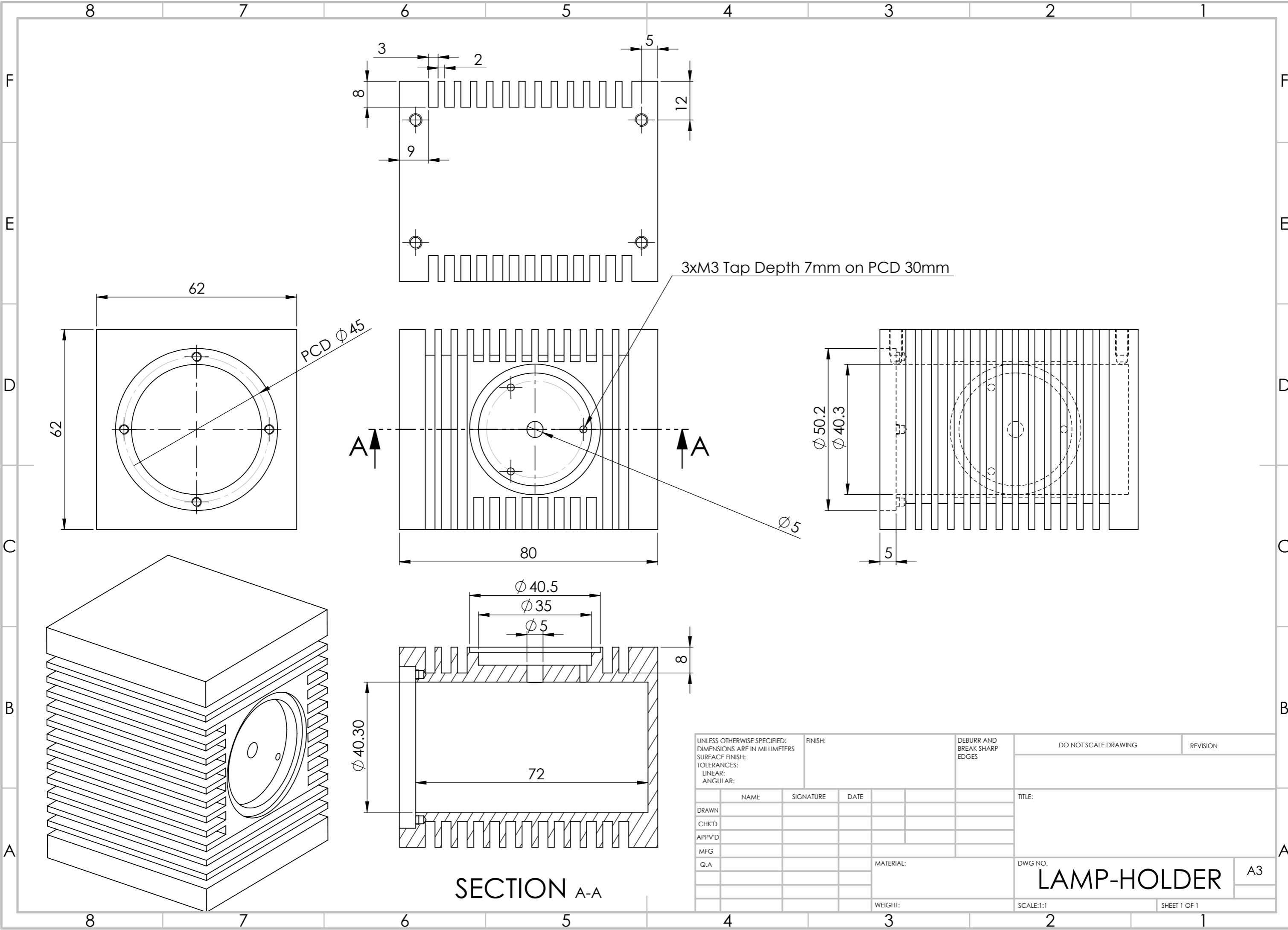

| | | | | | | | | | | | |
|---|--|--|---------|--|------------------------------------|--|----------------------|--|--------------|--|--|
| UNLESS OTHERWISE SPECIFIED: DIMENSIONS ARE IN MILLIMETERS SURFACE FINISH: TOLERANCES: LINEAR: ANGULAR: | | | FINISH: | | DEBURR AND BREAK SHARP EDGES | | DO NOT SCALE DRAWING | | REVISION | | |
| DRAWN | | | NAME | | SIGNATURE | | DATE | | TITLE: | | |
| CHK'D | | | | | | | | | | | |
| APPV'D | | | | | | | | | | | |
| MFG | | | | | | | | | | | |
| Q.A | | | | | | | MATERIAL: | | DWG NO. | | |
| | | | | | | | | | LAMP-HOLDER | | |
| | | | | | | | WEIGHT: | | SCALE:1:1 | | |
| | | | | | | | | | SHEET 1 OF 1 | | |

SECTION A-A

LAMP-HOLDER

A3

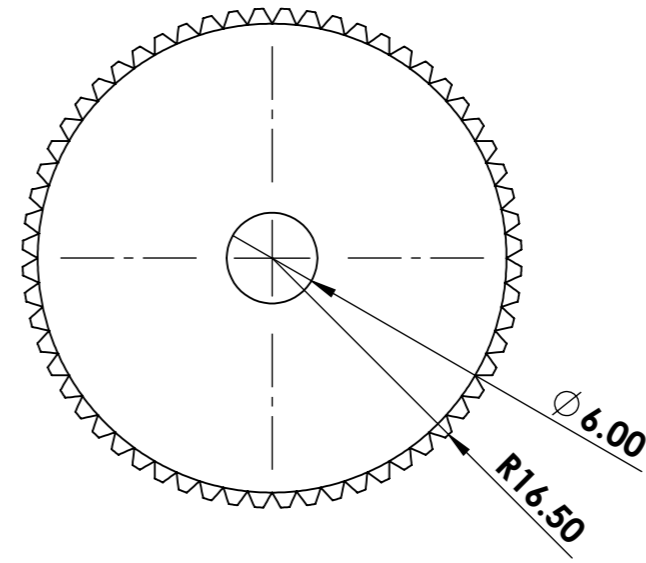
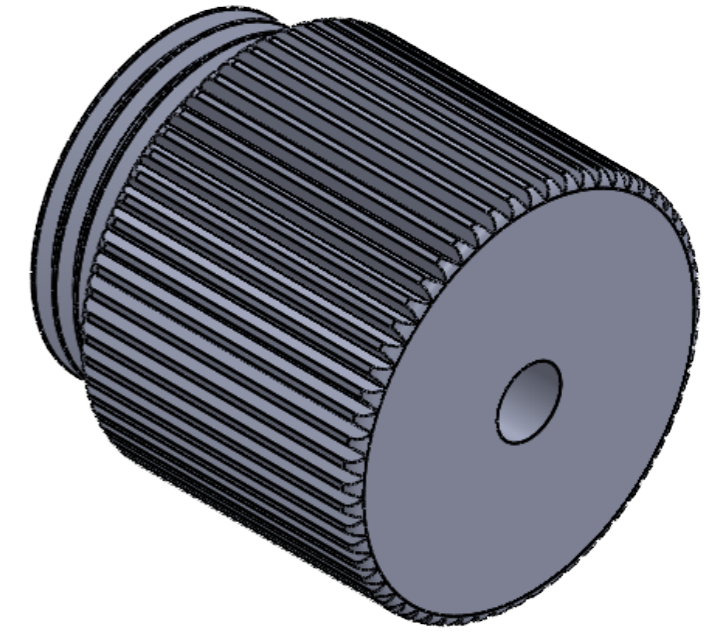
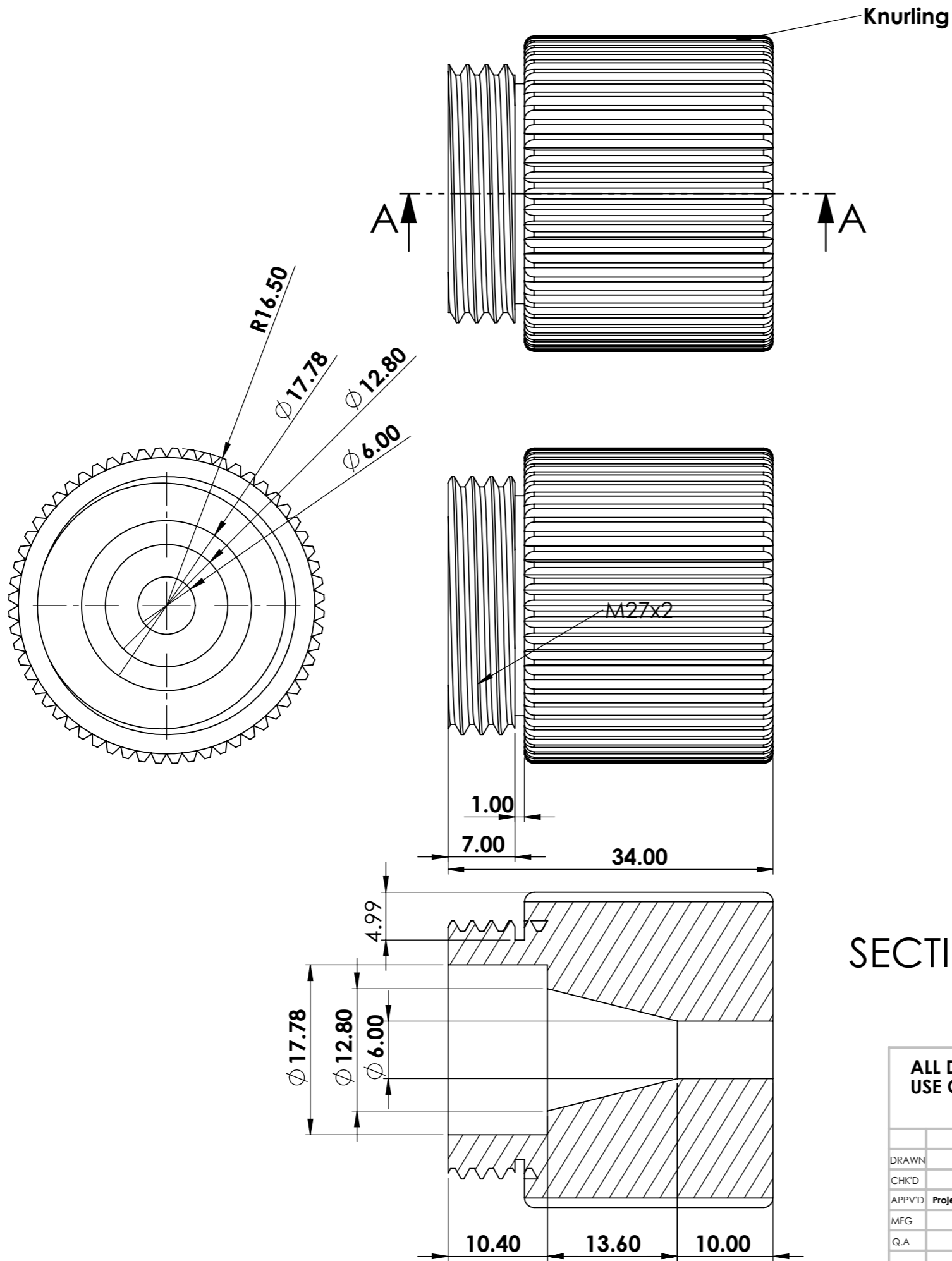

SECTION A-A

| | | | | | | | | | |
|---|--|--|--|--|--|---|--|-----------------------------|--|
| ALL DIMENSIONS ARE IN MM USE GENERAL TOLERANCE CHART | | | | DEBUR AND BREAK SHARP EDGES | | DO NOT SCALE DRAWING | | QUANTITY=01 | |
| | | | | | | CSIR-CSIO | | | |
| | | | | | | TITLE: | | | |
| | | | | | | LIGHT SOURCE ADAPTER | | | |
| | | | | | | DWG NO. CSIO/MDF/JJM/1086/2022/003 | | A4 | |
| | | | | | | AL | | | |
| | | | | | | WEIGHT: | | SCALE: DO NOT SCALE DRAWING | |
| | | | | | | | | SHEET 1 OF 1 | |

| | NAME | SIGNATURE | DATE | | |
|--------|------------------|-----------|------|--|--|
| DRAWN | ANIL | | | | |
| CHK'D | SAGAR | | | | |
| APPV'D | Project Incharge | | | | |
| MFG | | | | | |
| Q.A | | | | | |

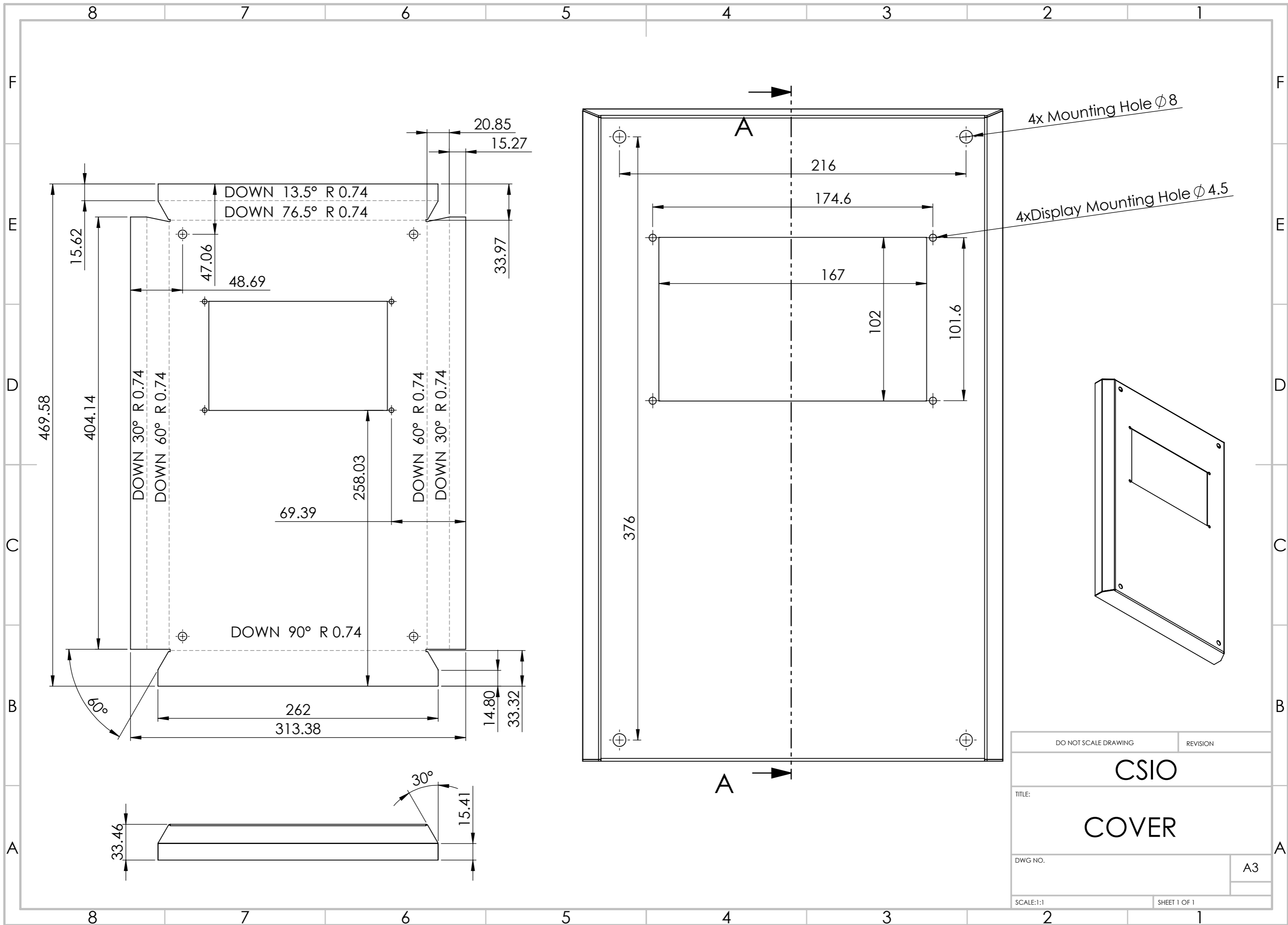

| | | | |
|----------------------|--|--------------|----|
| DO NOT SCALE DRAWING | | REVISION | |
| CSIO | | | |
| TITLE: COVER | | | |
| DWG NO. | | | A3 |
| SCALE: 1:1 | | SHEET 1 OF 1 | |

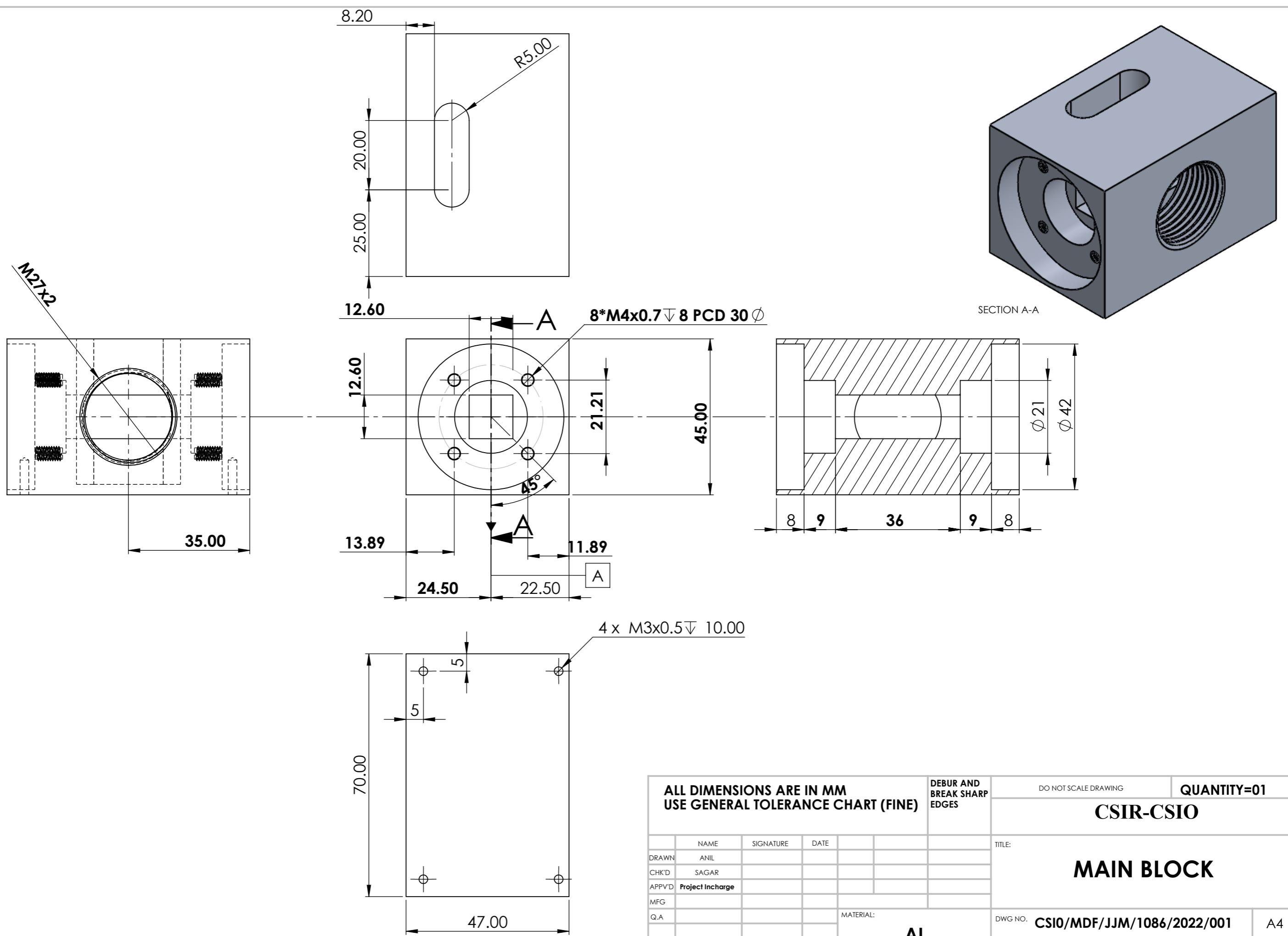

| | | | | | | | | | |
|--|--|--|--|--|--|---|--|--------------------|--|
| ALL DIMENSIONS ARE IN MM USE GENERAL TOLERANCE CHART (FINE) | | | | DEBUR AND BREAK SHARP EDGES | | DO NOT SCALE DRAWING | | QUANTITY=01 | |
| | | | | | | CSIR-CSIO | | | |
| | | | | | | MAIN BLOCK | | | |
| | | | | | | TITLE: | | | |
| | | | | | | DWG NO. CSIO/MDF/JJM/1086/2022/001 | | A4 | |
| | | | | | | SCALE: DO NOT SCALE DRAWING | | SHEET 1 OF 1 | |

| | NAME | SIGNATURE | DATE | | |
|--------|------------------|-----------|------|-----------|--|
| DRAWN | ANIL | | | | |
| CHK'D | SAGAR | | | | |
| APPV'D | Project Incharge | | | | |
| MFG | | | | | |
| Q.A | | | | | |
| | | | | MATERIAL: | |
| | | | | AL | |
| | | | | WEIGHT: | |

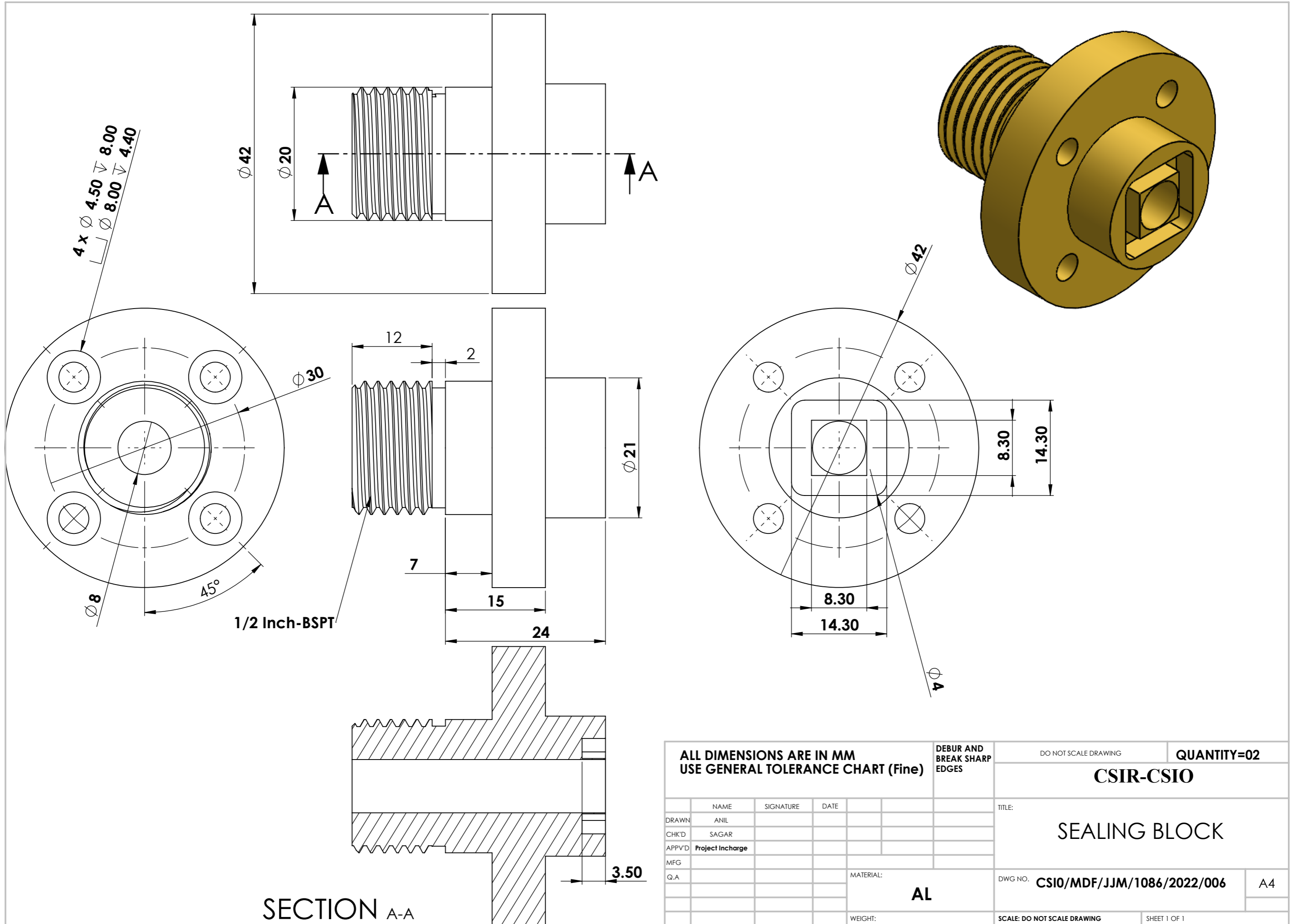

SECTION A-A

| | | | | | | | | | |
|--|--|--|--|-----------------------------------|--|---|--|--------------|--|
| ALL DIMENSIONS ARE IN MM USE GENERAL TOLERANCE CHART (Fine) | | | | DEBUR AND BREAK SHARP EDGES | | DO NOT SCALE DRAWING | | QUANTITY=02 | |
| | | | | | | CSIR-CSIO | | | |
| | | | | | | TITLE: SEALING BLOCK | | | |
| | | | | | | DWG NO. CSIO/MDF/JJM/1086/2022/006 | | A4 | |
| | | | | | | SCALE: DO NOT SCALE DRAWING | | SHEET 1 OF 1 | |

| | | | | | | | | | |
|--------|------------------|-----------|------|--|--|------------------------|--|--|--|
| | NAME | SIGNATURE | DATE | | | | | | |
| DRAWN | ANIL | | | | | | | | |
| CHK'D | SAGAR | | | | | | | | |
| APPV'D | Project Incharge | | | | | | | | |
| MFG | | | | | | | | | |
| Q.A | | | | | | | | | |
| | | | | | | MATERIAL: AL | | | |
| | | | | | | WEIGHT: | | | |