



सीईएसआईआर-केन्द्रीयवैज्ञानिकउपकरणसंगठन

CSIR-Central Scientific Instruments Organisation

सैक्टर 30 सीचंडीगढ़ Sector-30C, Chandigarh 160 030

ई-मेल / e-mail:aashish_garv.csio@csir.res.in

ई-मेल /रजिस्टर्ड/ स्पीड पोस्ट/ कूरिपर द्वारा

एल.पी.सी.एन.आई.टी.सं./LPC NITNo.:	CSIO/iSenS/LPC-2026-27/04/01
दिनांक / Date:	29.04.2026
निविदाप्राप्तिकाअंतिमसमयएवंदिनांक / Date & time of receipt of tender	12.05.2026 (Forenoon)
निविदाखोलनेकासमयएवंदिनांक / Date & time of opening of Tender	12.05 .2026 (Afternoon)

महोदय/Sir,

हम उपस्कर/सामग्री खरीदनेके इच्छुक हैं। इससे सम्बंधित नियम व शर्तेंव अन्य दस्तावेज संलग्न हैं./We are interest to purchase the below given items/attached items for R&D purpose. The terms and conditions and other documents are attached herewith. -

S. No.	Item Name with Complete Specification	Quantity
1.	Custom board design and fabrication for following modules: 1) Display driver with Power Module as per design 1 2) Display driver with separate power module as per design 2 3) LED Backlight Module as per design 3 See Annexure-1 for complete specification	02 02 04

एकल बोली प्रणाली में मुहरबंद निविदाएं आमंत्रित की जाती हैं। कवर के ऊपर , स्थानीय खरीद समिति (एल पी सी) की एन आई टी, एलपीसी एनआईटी संख्या, नियत तिथि, खोलने की तिथि अंकित होनी चाहिए और **निदेशक, सी.एस.आई.आर.-केन्द्रीय वैज्ञानिक उपकरण संगठन, सेक्टर- 30 सी, चंडीगढ़-160030** तथा **ध्यान-आकर्षण---** प्रमुख, नाम और पदनामको संबोधित होनी चाहिए । मुहरबंद कवर में निम्नलिखित शामिल हैं। बोली ई-मेल के द्वारा भी भेजी जा सकती है । /The sealed tenders are invited in **Single bid system**.Covershall be superscribed with **NIT of Local Purchase Committee ,LPC NIT no., Due date, Date of opening** and addressed to the **Director, CSIR-Central Scientific Instruments Organisation, Sector- 30 C, Chandigarh-160030** and also mentioned- **Kind Attention Mr. Ashish Gaurav**

The Sealed cover contains the followings. **The bid/quotation may also be submitted through E-mail aashish_garv.csio@csir.res.in, CC vikash.chandra.csio@csir.res.in and bhargab.das.csio@csir.res.in**

Documents/Papers to be submitted with Bid: **(In the absence of these, bid/Quotation will be summarily rejected).**

Sl. No.	Documents required
A.	Duly filled, signed and stamped Bid Securing Declaration (BSD) as per Annexure - I
B.	Duly filled, signed and stamped Tender acceptance letter as per format Annexure - III
C.	Duly filled, signed and stamped Code of Integrity as per format Annexure - IV
D.	Duly filled, signed and stamped Certificate of Price Reasonability as per Annexure V
E.	Technical Bid along with Technical Literature Document – self attested copies of technical literature of item(s) with details of specifications.
F.	A copy of self- certification about the products offered in this tender meets local content requirement for Class- I Local supplier (local content minimum 50%) or Class- II Local supplier (local content minimum 20%) or Non- Local supplier (local content less than 20%) as per Make in India Policy No. P-45021/2/2017-PP(BE-II) dt- 16/09/2020 .The details of the location(s) at which the local value addition is made should also be mentioned in the self-certification as per Annexure – VI .
G.	A copy of certificate (a model certificate is given in the attached) regarding Restrictions on procurement from a bidder of a country which shares a Land Border with India wherein if any bidder from a country which shares a land border with India will be eligible to bid in any procurement whether of goods, services or work only if the bidder registered with the competent authority as per Annexure - VII
H.	Copy of duly filled, signed and stamped Bank account details of the firm on their letter head as per our format as per Annexure - VIII
I.	Duly filled, signed and stamped Price Schedule (in INR only) as per Annexure - IX

निविदा प्रस्तुत करने से पहले, कृपया संलग्न नियमों और शर्तों को ध्यान से पढ़ें, जिन पर निविदाएं अवार्ड की जाएंगी और सफल बोलीदाता द्वारा कार्यान्वित किया जाएगा।/ Before submitting the quotation/ bid, please go through the enclosed terms and conditions on which the purchase order will be awarded and shall be executed by the successful bidder.

(_____)

For & on behalf of CSIR-CSIO

संलग्न/Encl.:

1. नियम एवं शर्तें/ Terms & Conditions अनुलग्नक-I से IX तक /Annexure- I to IX

नियमऔरशर्तें /Terms & Conditions

1. The quotation/bid must be in the form furnished by the Purchaser/as per tender specifications and should be free from corrections/erasures. In case there is any unavoidable correction it should be properly attested. If not, the quotation will not be considered. Please refer our complete tender terms & conditions. Ensure to provide the required documents to avoid rejection.
2. The rates should be in **INR only** and also on FOR.CSIO, Chandigarh (Central Stores) basis. Where there is no mention of packing, forwarding, freight, insurance charges, taxes etc. **such offer shall be rejected as incomplete.** The bidder should also give a clear cut break up of quoted price to facilitate the proper comparison **failing which the bid would be summarily ignored/rejected.** **Our GST No. is 04AAATC2716R1ZN**
3. The Bidder is expected to examine all instructions, forms, terms & conditions, and specifications in the NIT documents. Failure to furnish all information required by the bidding documents or submission of a bid not substantially responsive to the bidding documents in every respect will be at the Bidder's risk and may result in rejection of its bid.
4. The quotations/ bids will be accepted through offline (Indian post/ courier) preferably as well as through e-mail. If the quotation is submitted through E-mail, then bidder should attach scan copies of all duly filled, signed and stamped required documents (mandatory& others). The tender received in any other mode will not be accepted and will be ignored. It may kindly be noted that your bid should contain all the mandatory documents as mentioned in NIT. **If not, the bid will be summarily rejected.**
5. Bid/ Quotation received after due date and time will not be accepted under any circumstances.
6. On the event of award of purchase order in your favour, you need to submit a **Performance Bank Guarantee (PBG)** valid for a period of 60 days beyond the Warranty period of..... **(retain only, if applicable). In case of all capital items (equipment, machine etc) costing above 2.5 lakh rupees , the successful bidder will have to submit PBG (@3% of total value) within 21 days from the date of issuing purchase order.**
7. The acceptance of the quotation will rest with the competent authority of **Central Scientific Instruments Organisation, Sector-30, Chandigarh** who does not bind himself to accept the lowest quotation and reserves the right to himself to reject, or partially accept any or all the quotations received without assigning any reason.
8. **Bid Validity:** Bid should be valid for a minimum period of **90 days** from the date of opening of the quotation, **failing which the offer will be ignored/rejected.**
9. The bidder must submit the Price Schedule as per Annexure-X.
10. Technical bid along with Technical Literature/Pamphlets should also be enclosed wherever applicable **and only mentioning "YES" in Questionnaire about fulfilling the parameters of specifications will be treated as incomplete and bid will not be accepted.** Complete specification with manufacturer's name and address should be given while quoting.
11. Prices are required to be quoted in units indicated in the enquiry. When quotations are given in terms of other units, relationship between two sets of units should be furnished. Quantity discounts, if any should also be indicated. The items should be quoted indicating the serial No. of our RFQ/NIT.

12. In cases of quoting on behalf of Indian Manufacturer, one dealer/stockist cannot represent two manufacturers or quote on their behalf in a particular tender enquiry. One manufacturer can also authorize only one stockist/dealer. There can be only one bid from the Indian authorised dealer on behalf of only one principal/manufacturer.
13. **Taxes as are applicable should be indicated clearly failing which the offer shall not be considered and rejected.** This lab is registered with Dept. of Scientific & Industrial Research, Govt. of India and concessional GST & IGST are levy able vide Govt. Notification No. 45/2017-Central Tax (rate) & No. 45/2017-Integrated Tax (rate) dated 14.11.2017 for R& D products . **No Custom duty exemption certificate will be given in any case.**
14. **Delivery period** required for supplying the material should be invariably specified in the quotation. The offered delivery period shall have to be strictly adhered to in case an order is placed.
15. **Liquidated Damages Clause for delays:** The applicable rate is 0.5% per week and maximum deduction is 10% of the contract price. **Installation/commissioning:** Equipment/Instruments are required to be commissioned/installed/ demonstrated successfully immediately or within 30 days from the date of receipt of the system in CSIO by the manufacturer or by their authorized Agent, **failing which the Liquidated Damage Clause will be applicable as mentioned above.**
16. If the deliveries are not maintained and due to that account the purchaser is forced to buy the material at your risk and cost from elsewhere, the loss or damage that may be sustained there by will be recovered from the defaulting supplier.
17. **Warranty Period:** Please mention the warranty period of equipment, which should be from the date of satisfactory installation. **The offer received for lesser warranty, as asked for in the tender, will be rejected/ignored.** All supplies are subject to inspection and approval before acceptance. Manufacturer warranty certificates and manufacturer/Government approved lab test certificate shall be furnished along with the supply, wherever applicable.
18. **Terms of Payment:** Our payment terms are 100% (hundred percent) within 30 (thirty) days on receipt, acceptance, installation & commissioning (if required), training (if required) and confirmation of PBG (if required) of material at our site in good condition. Please inform your Bank details as per our format for RTGS payment. Banking details should be available on Bill/invoice. **Advance payment will be not given in any condition.** Other mode of payment may be decided by the by the Committee with the approval of the Director. **Should furnish your PAN & GST Number in your quotation & on Invoice. TDS would be recovered as per rules.**
19. **Reasonability of Prices/Fall Clause**
 - i. Quote best minimum prices applicable for a CSIO, Research Institution, leaving no scope for any further negotiations on prices.
 - ii. **The quoting party should give a certificate to the effect that the quoted prices are the minimum and they have not quoted the same item on lesser rates than those being offered to CSIO to any other customer nor they will do so till the validity of offer or execution of the purchase order, whichever is later.**
 - iii. Copies of at least two recently supplied orders of the last two years received from other customers along with details of such supply orders in India for the same item/model may be submitted with the offer giving reasons of price

difference of their supply order & those quoted to us, if any. The party must give details of identical or similar equipment, if any, supplied to any CSIR lab during the last three years along with the final price paid and Performance certificate from them.

20. Certificate of undertaking that the equipment is of latest technology & will not be obsolete within 5 years after warranty will be attached with the offer. All essential spares parts of the offered equipment will available with the manufacturer for a period of at least 5-7 years after warranty period which will be required at later stage.
21. **MSME purchase preferences** will be given to the eligible supplier as per the Govt. guidelines subject to submission of proper document as per policy or UdyogAdhar/Udyog Memorandum in respective category.
22. Code of Integrity has to be maintained by Bidders/Suppliers/Contractors by maintaining highest standards of ethics in the Procurement process and prohibits corrupt practice/Fraudulent practice/Anti- Competitive practice / Coercive Practice/ Conflict of Interest and Obstructive practice either directly or indirectly during the process of contract.
23. Tender conditions (printed on the reverse), if any, or otherwise sent along with the tender shall not be binding on us.
24. A copy of **self- certification** about the products offered in this tender meets local content requirement for **Class- I Local supplier (local content equal to or more than 50%)** or **Class- II Local supplier (local content more than 20% but less than 50%)** as per **Make in India Policy No. P-45021/2/2017-PP(BE-II) dt- 16/09/2020, should be attached with bid.** The details of the **location(s)** at which the local value addition is made should also be mentioned in the self-certification.

Exemption will be given as per the policy of Govt Of India. Beyond the exemption limit, Non-local supplier will not participate in any tender, their bid will be rejected .Whenever Govt will issue any amendment in this policy, and the same will be applicable accordingly.
25. A copy of certificate regarding **Restrictions on procurement from a bidder of a country which shares a Land Border with India** wherein if any bidder from a country which shares a land border with India will be eligible to bid in any procurement whether of goods, services or work only if the bidder registered with the competent authority, should be attached with bid.
26. Above instructions & our standard terms & conditions must be complied failing which your offer may be liable for rejection.
27. Director, CSIR-CSIO, Chandigarh reserves the right to reject all or even the lowest quotation without assigning any reason. All disputes shall be settled in the courts of Chandigarh Jurisdiction only

Yours faithfully,
For & on behalf of CSIR-CSIO

Annexure-1: Custom board design and fabrication for Display Driver Module and Power Module

Custom board design and fabrication for following modules:

- 1) Display driver with Power Module as per design 1 (Quantity 2)
- 2) Display driver with separate power module as per design 2 (Quantity 2)
- 3) LED Backlight Module as per design 3 (Quantity 4)

Table: Detailed Specification

#	Deliverables and design considerations	Value	Remarks
1	Display Driver Module including Power Design-1 (Quantity 2 Nos)	<ul style="list-style-type: none"> • Display device: as per DLP5530Q1EVM • Configuration interface (I²C / SPI) • Video In: - Micro HDMI • Material: FR-4 • Dimension: < 180*85 mm 	<ul style="list-style-type: none"> • Follow TI reference schematic • Dimension: shown in Figure 1
2	Display Driver Module Design-2 (Quantity 2 Nos)	<ul style="list-style-type: none"> • Display device: as per DLP5530Q1EVM • Configuration interface (I²C / SPI) • Video In: - Micro HDMI • Material: FR-4 • Dimension as per Figure 2 	<ul style="list-style-type: none"> • As per Figure 2 (a) • Follow TI reference schematic
3	Power Module (Quantity 2 Nos)	<ul style="list-style-type: none"> • Power In: 10-18 V DC • Filtered power O/P: 6.5 V @ 3A • Dimension: < 65*80 mm • Material: FR-4 	<ul style="list-style-type: none"> • Follow TI reference schematic • As per Figure 2 (b)
4	LED Backlight Module (Quantity 4 Nos)	<ul style="list-style-type: none"> • Source: LED • Dimension: < 40*30 mm • Connectors: Polarized SMD • Material: Copper/Aluminum 	<ul style="list-style-type: none"> • Follow TI reference schematic • As per Figure 3
5	Signal and power Integrity & Layout Considerations	<ul style="list-style-type: none"> • As per TI recommendation • Differential pair routing (LVDS / MIPI) • Controlled impedance • Length matching constraints 	<ul style="list-style-type: none"> • Components placement drawing will be shared
6	Testability & Diagnostics	<ul style="list-style-type: none"> • Test points for critical signals 	<ul style="list-style-type: none"> • All the regulated power o/p and enable signals
7	Documentation	<ul style="list-style-type: none"> • Schematic diagrams • PCB layout and Gerber files • Bill of Material (BoM) • Test and validation report • Signal and Power Integrity Report • ATP • Operating manual 	<ul style="list-style-type: none"> • Top Level design document will be shared
8	Warranty	One year	For all modules

Annexure-1: Custom board design and fabrication for Display Driver Module and Power Module

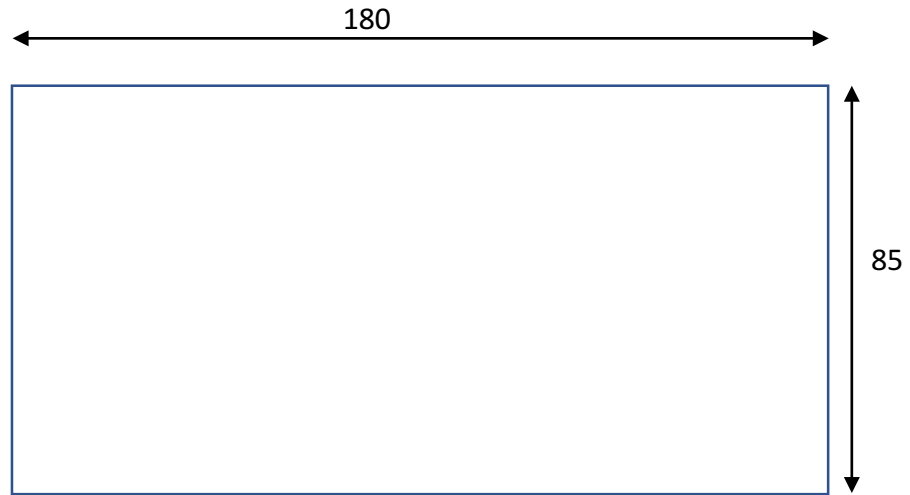
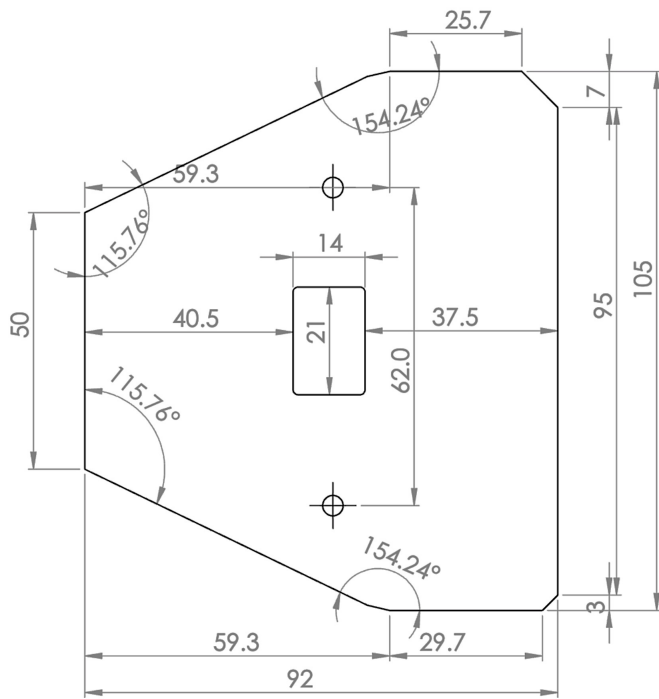
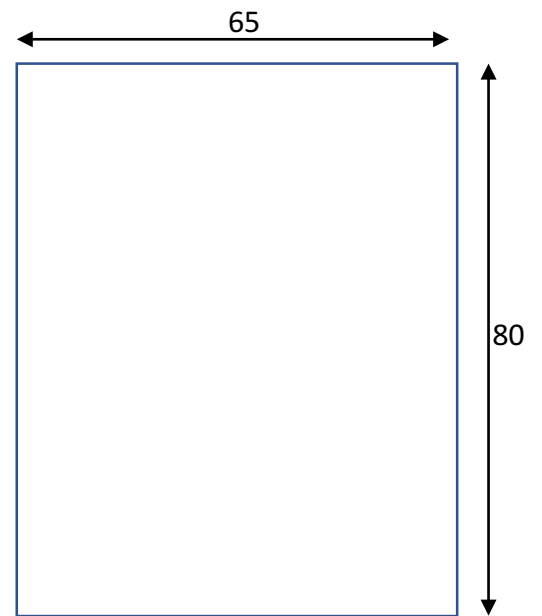

Figure-1: Design 1 (size in mm)



(a) Driver Module



(b) Power Module

Figure-2: Design 2 (size in mm)

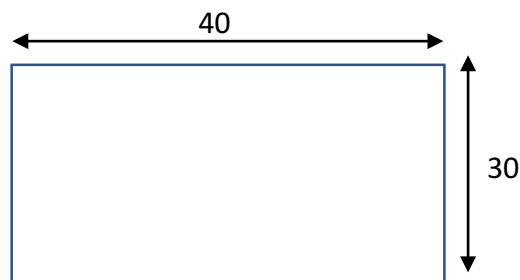

Figure-3: Design 3 LED Backlight (size in mm)